

-MAP

HIGH-PERFORMANCE AIRBORNE LASER MAPPING SOLUTIONS



LEARN MORE

ELMAP Airborne LiDARs are a series of high-performance mid- and high-range laserscanners designed for cost-effective airborne laser mapping with fixed-wing aircraft, helicopters, and gyrocopters. They provide highly accurate measurements in a compact and lightweight package that can easily be installed even on small survey aircraft. ELMAP systems make advanced airborne lidar technology affordable. They are the ideal choice for replacing outdated or updating older systems with state-of-the-art performance.

The ELMAP-V lidar sensor was designed specifically for use in aircraft with small diameter camera hatches, or for integration in stabilizing camera mounts. With its vertical layout and the resulting small footprint at the aperture it may be inserted into the camera well or camera mount so that the full scan angle of 80° remains available in such installations.



KEY FEATURES

- Industry-leading field-of-view of 80°
- Up to 1.400.000 shots-per-second on the ground
- High range up to 4300 m at 20% reflectance
- Linear, uniform scan pattern with parallel scan lines
- High-resolution waveform digitization for every shot
- Integrated removable data storage on standard high-capacity SSDs
- Compact size and the lowest power consumption of their class
- IMU compartment for installation by customer
- Friendly price tag

APPLICATIONS



WIDE-AREA
TOPOGRAPHIC
MAPPING



FORESTRY



MOUNTAINOUS
TERRAIN



URBAN AREA
MAPPING



INFRASTRUCTURE
MONITORING



CORRIDOR



AGRICULTURE



MINING



ICE SHEET
AND GLACIER
MONITORING

SPECIFICATIONS	ELMAP15-V	ELMAP30-V
Ranging method	laser pulse time-of-flight, waveform digitization	
Measurement range ¹⁾	2500 m	4300 m
Ranging precision ²⁾	0.007 m	
Ranging accuracy ³⁾	0.03 m	
Laser pulse rate	100 - 1.600 kHz	
Effective measurement rate ⁴⁾	90.000 - 1.400.000 meas/s	
Data output ^{5) 6) 7)}	range, intensity, pulse width for every target/return	
Beam divergence ⁸⁾	0.3 mrad	
Laser eye-safety class	Class 3B	
Beam deflection	polygon mirror scanner	
Scan pattern	linear parallel scan lines	
Field of View	10° - 80°	
Scan rate	20 - 250 scans lines/s	
Angular accuracy	0.0025°	
Operational altitude ⁹⁾	up to 2100 m	up to 3600 m
Swath width ¹⁰⁾	up to 3000 m	up to 5150 m
Data storage capacity ¹¹⁾	1TB internal (2.2 h) 4TB removable (8.8 h)	

INTERFACES	
Sensor control and monitoring	GigaBit Ethernet
GNSS synchronization	Serial RS-232 (time-tag), 1 PPS inputs
Sensor control	USB 2
External storage	USB 3
Sensor monitoring	HDMI output
Remote control and laser safety	RemoteBox (LEMO)
Mission management or camera control	GPIO (LEMO)
Data storage	SATA 6 (SSD bay)

1) to single, flat target perpendicular to beam, entirely covering laser footprint, with 20% diffuse target reflectance at laser wavelength, 40 km visibility, 95% detection probability

2) standard deviation one sigma to single flat target perpendicular to beam, entirely covering laser footprint, at range of 150 m

3) RMS one sigma to single, flat target perpendicular to beam, entirely covering laser footprint, with 20% diffuse reflectance, at range of 1200 m

4) shots-on-the ground at 80° FOV - each measurement may consist of returns from multiple targets

5) derived from recorded waveform data in post-processing; minimum return amplitude required for pulse detection, i.e. targets at large distance, with small cross section, or low reflectance may go undetected

6) true range is derived in post-processing using RDA (range disambiguation) technology for an unlimited number of range zones

7) data gaps and banding between range zones are minimized using Adaptive PRF technology based on Riegl Patent No. WO2016/201469 and used under license

8) $1/e^2$ value

9) flat surface, 20% reflectance, 30km visibility, 100 kHz PRF, 100% output power, 60° FOV

10) flat surface, 85% of max. AGL, 80° FOV

11) minimum endurance for continuous (uninterrupted) data acquisition, at maximum data rate

PRODUCTIVITY

Acquisition rate vs. Point density

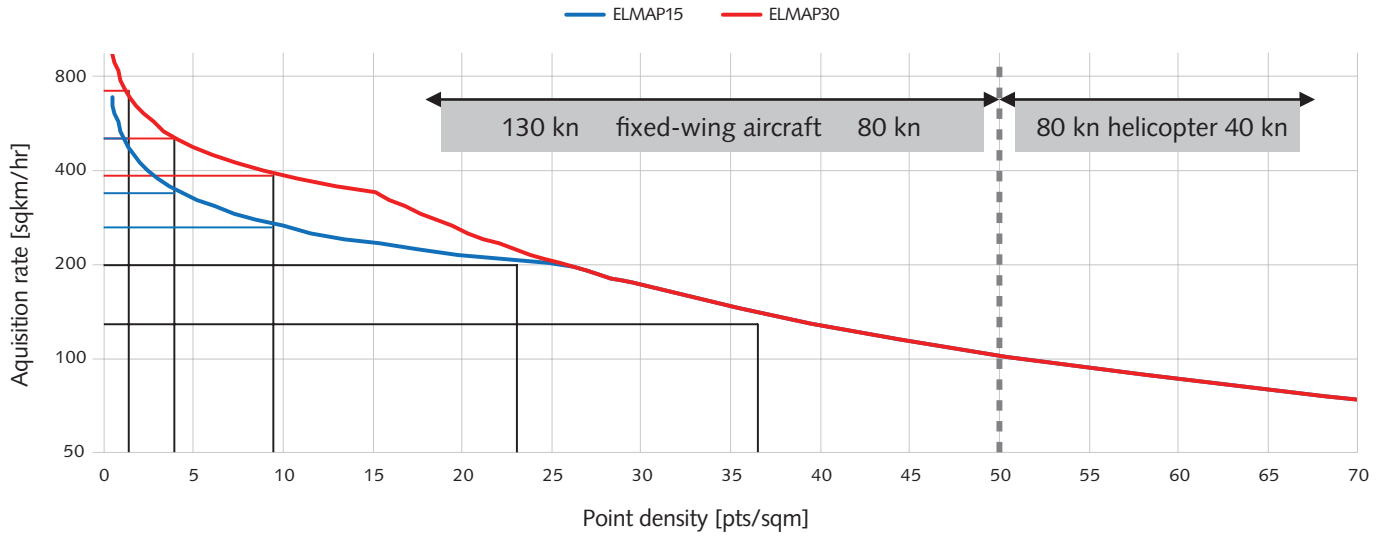

Avg. point density		1 pt/m ²	4 pts/m ²	10 pts/m ²	25 pts/m ²	40 pts/m ²	70 pts/m ²
Ground speed		130 kn	130 kn	130 kn	130 kn	100 kn	60 kn
Flying height	ELMAP30	1925 m	1250 m	960 m	505 m	420 m	400 m
	ELMAP15	1280 m	860 m	640 m	505 m	420 m	400 m
Swath width	ELMAP30	3230 m	2100 m	1610 m	850 m	705 m	670 m
	ELMAP15	2150 m	1440 m	1075 m	850 m	705 m	670 m
Acquisition rate	ELMAP30	780 km ² /h	504 km ² /h	390 km ² /h	205 km ² /h	130 km ² /h	75 km ² /h
	ELMAP15	520 km ² /h	348 km ² /h	264 km ² /h	205 km ² /h	130 km ² /h	75 km ² /h

Ground speed 40 -130 kn, FOV 80°



PERFORMANCE ENVELOPE

ELMAP30-V

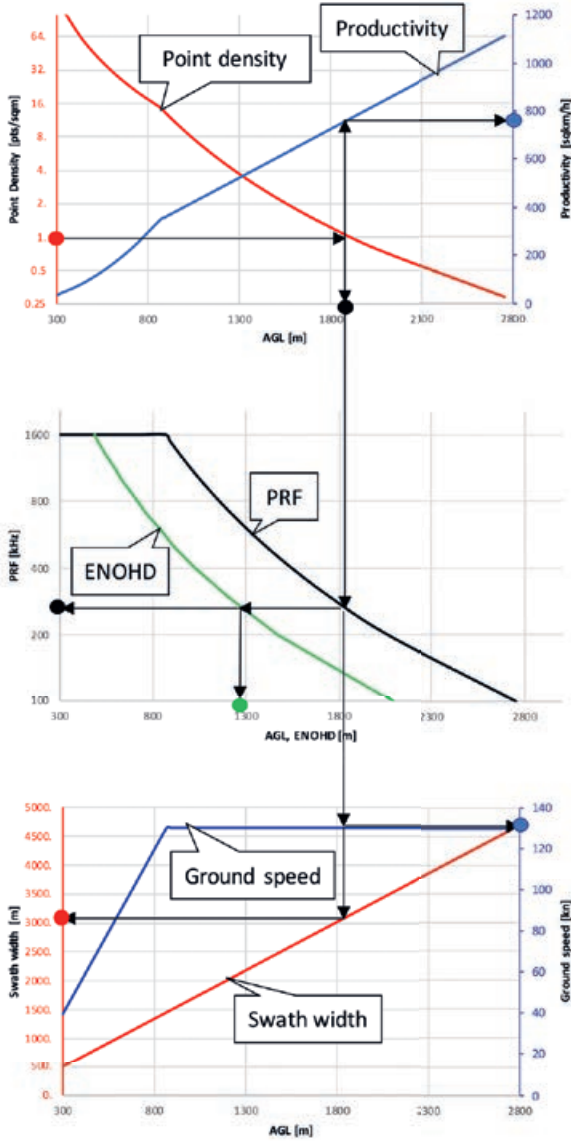

ELMAP15-V

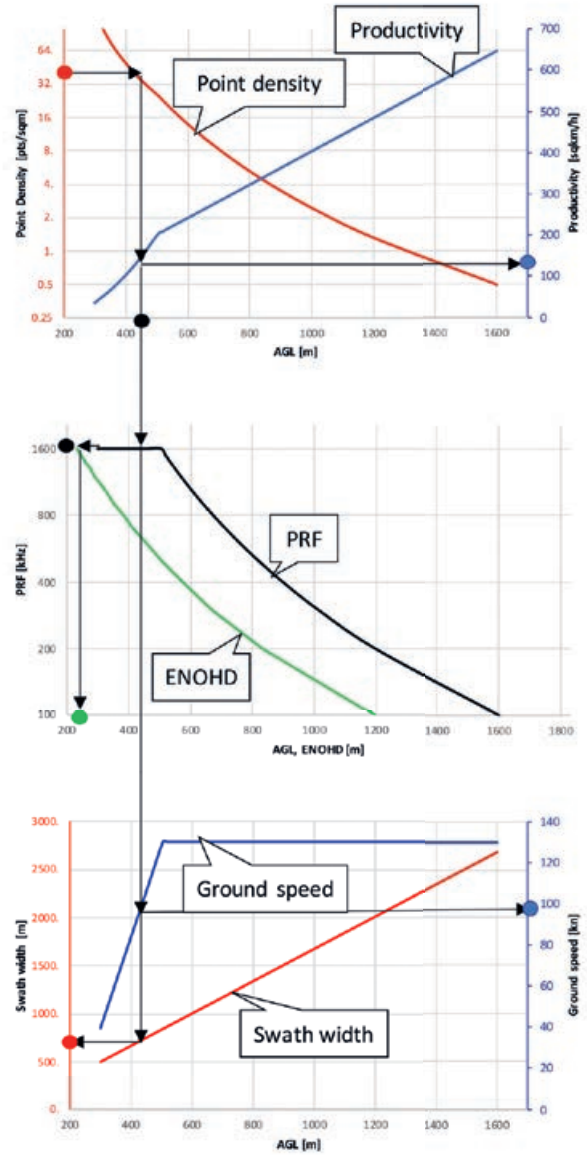

	ELMAP30-V with 80° FOV	ELMAP15-V with 80° FOV
Required avg. point density	1 pt/m ²	40 pts/m ²
=> AGL	1925 m	430 m
=> Ground speed	130 kn	98 kn
=> PRF	240 kHz	1600 kHz
=> Swath width	3230 m	724 m
=> Productivity	780 km ² /h	132 km ² /h
=> ENOHD	1350 m	230 m

DIMENSIONS

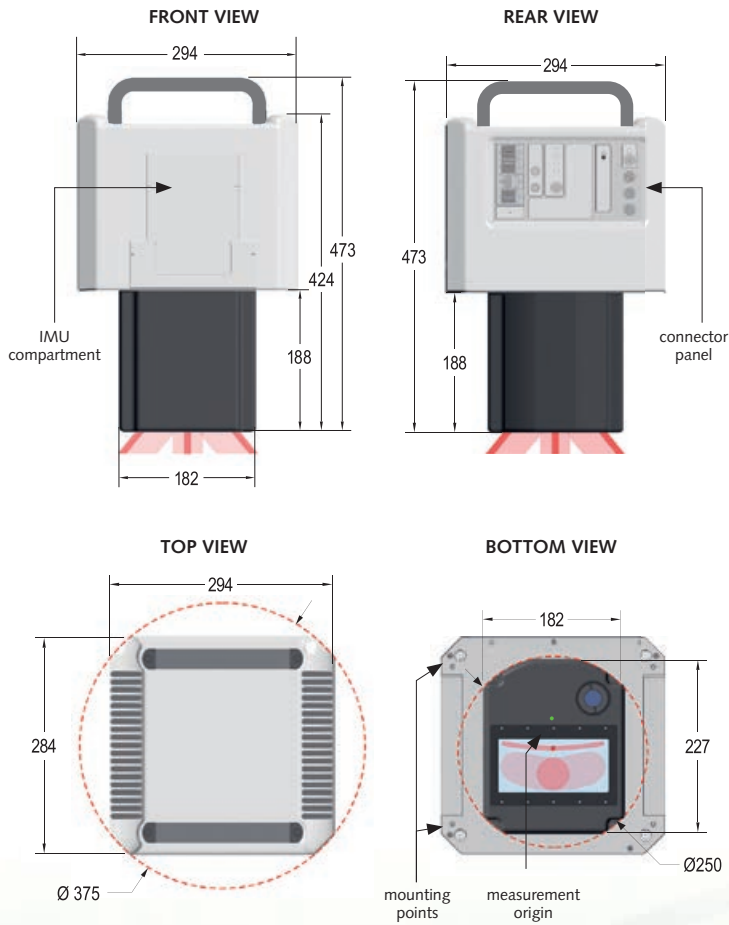

IMU COMPARTMENT

The ELMAP-V lidar sensor provides a compartment for integrating a wide variety of IMUs inside the instrument. The IMU is mounted to a removable IMU carrier which is inserted into the IMU compartment and provides a precisely aligned and mechanically rigid connection to the instrument.

The IMU compartment will house many IMUs ranging from economical MEMS IMUs with moderate accuracy up to high-end FOG IMUs complementing the instrument's superior accuracy for optimum measurement results.

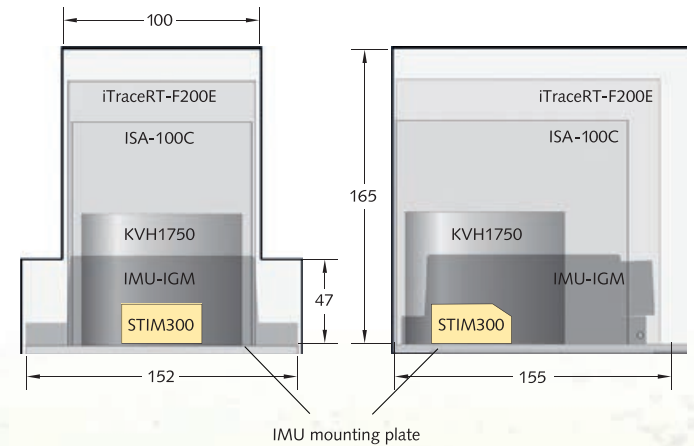

Dimensions	304 x 294 x 473 mm (LxWxH)	
Weight	15 kg	
IMU mounting facilities	IMU compartment with removable IMU mounting plate	
Power requirements	ELMAP15-V	ELMAP30-V
	18 - 32 VDC, 100 W (avg.) 110 W (max during startup)	18 - 32 VDC, 110 W (avg.) 125W (max during startup)
Operating conditions	0°C - 40°C, 0 - 5000m MSL	

Max. IMU Dimensions (LxWxH)	155 x 110 x 165 mm 155 x 152 x 47 mm (lower section)
IMU carrier plate	165 x 152 x 5 mm
Suitable IMUs (selection)	<ul style="list-style-type: none"> • Sensoror STIM300 (MEMS) • Novatel IMU-IGM (MEMS) • KVH 1750 (FOG) • Honeywell HG4930 (MEMS) • Litef ISA-100C (FOG) • IGI Aerocontrol (FOG) • Emcore EN300 (FOG)

INSTALLATION EXAMPLE



GLASAIR SPORTSMAN 4X4



SOMAG DSM400 MOUNT

ACCESSORIES

- RemoteBox remote control unit with laser safety keyswitch and emergency button
- One removable SATA SSD (4TB capacity)
- SATA docking station
- Removable IMU carrier
- Set of cables and spare fuses
- Transportation case
- Perpetual Geocode lidar raw data processing and geocoding software license
- Software utilities
- Operating manuals and documentation

OPTIONS

- Customized adapter with vibration isolators and spacers for mounting the sensor in the customer's aircraft
- Sunlight-readable touchscreen monitor and ruggedized keyboard
- Ruggedized tablet computer
- Integrated GNSS receiver and IMU
- Stabilizing mount
- 12V voltage converter
- Boresight calibration and strip alignment software
- Point-cloud visualization and post-processing software

Class 3B Laser Product according to IEC60825-1:2014

Complies with 21 CFR 1040.10 and 1040.11 except for conformance with IEC 6085-1 Ed. 3., as described in Laser Notice No. 56, dated May 8, 2019



INVISIBLE LASER RADIATION
AVOID EXPOSURE TO BEAM
CLASS 3B LASER PRODUCT

MAX. AVERAGE OUTPUT <400 mW
PULSE DURATION <6 ns
WAVELENGTH 1530 nm
STANDARD IEC60825-1:2014 Ed.3



LEARN MORE



GeoLas Systems GmbH

Bernauer Str. 37a D-83229 Aschau i. Chiemgau / Germany

Tel: +49 8052 178 1485 | geolas-systems.com

Revised: 10-3-2023